

Design of Steel Structures II

Text: Jack C. McCormac, Stephen F. Csernak; Structural Steel Design - Fifth Edition, Pearson International Education

In all of the following problems, $F_y = 2400 \text{ daN/cm}^2$ and $F_u = 3700 \text{ daN/cm}^2$, unless noted otherwise.

All answers are to be provided in Iranian customary units (tons, Kgf or daN, m, cm, etc.) using steel sections available in Iran (IPE, IPB, L, U, etc.). Derive metric properties of steel and use $1 \text{ MPa} \approx 10 \text{ daN/cm}^2$, unless noted otherwise. Also, if necessary, convert the US customary units to metric units:

$$\begin{array}{lllll} 1 \text{ yd} = 3 \text{ ft} & 1 \text{ ft} = 12 \text{ in} & 1 \text{ in} \approx 2.5 \text{ cm} & 1 \text{ kip} \approx 454 \text{ daN} & 1 \text{ ksi} \approx 70 \text{ daN/cm}^2 \\ & 1 \text{ ft} \approx 30 \text{ cm} & 1 \text{ kip/ft} = 1488 \text{ kgf/m} & & 1 \text{ psf} \approx 4.9 \text{ daN/m}^2 \end{array}$$

Homework Set #2

Problem Number	Comments
----------------	----------

Use only LRFD method to solve the following questions.

- | | |
|-------|------------------------------------------------------------------------------------------------------------------------------------|
| 14.2 | Weld size=6mm, Plates are 30x1 cm & 20x1 cm with 60 cm overlap. |
| 14.5 | Weld size=6mm, plate width= 15 cm, weld length=20 cm. |
| 14.7 | $P_D=20 \text{ ton}$, $P_L=30 \text{ ton}$, Plates are 20x1.5 cm and 30x1.5 cm, weld size=8mm, design for both SMAW and SAW. |
| 14.10 | PL20x1.6 cm, weld size=8 mm, convert other dimensions to centimeters. |
| 14.12 | $P_D=35 \text{ ton}$, $P_L=30 \text{ ton}$, use L18x9x1.2 cm, take $F_y=3600 \text{ daN/cm}^2$ and $F_u=5200 \text{ daN/cm}^2$. |
| 14.15 | Weld size=8mm, $P_D=40 \text{ ton}$, $P_L=80 \text{ ton}$, use UNP280 with ST37 steel, gusset thickness=1cm. |

b. Base metal values (J4.2)

Shear yielding strength

$$R_n = 0.60 F_y A_{gv}$$

$$= 0.60 (50 \text{ ksi}) (0.75 \text{ in}) (22.5 \text{ in}) = 506.2 \text{ k}$$

LRFD $\phi = 1.00$	ASD $\Omega = 1.50$
$\phi R_n = (1.00)(506.2) = 506.2 \text{ k}$	$\frac{R_n}{\Omega} = \frac{506.2}{1.50} = 337.5 \text{ k}$

Shear rupture strength

$$R_n = 0.60 F_u A_{nv}$$

$$= 0.60 (65 \text{ ksi}) \left(2 \times \frac{1}{4} \text{ in} \right) (22.5 \text{ in}) = 438.7 \text{ k}$$

LRFD $\phi = 0.75$	ASD $\Omega = 2.00$	
$\phi R_n = (0.75)(438.7) = 329.0 \text{ k}$	$\frac{R_n}{\Omega} = \frac{438.7}{2.00} = 219.4 \text{ k}$	← controls

Weld values (60° V-groove weld)

$$R_n = 0.6 F_{EXX} A_{we}$$

$$= 0.6 (70 \text{ ksi}) \left(2 \times \frac{1}{4} \text{ in} \right) (22.5 \text{ in}) = 472.5 \text{ k}$$

LRFD $\phi = 0.75$	ASD $\Omega = 2.00$
$\phi R_n = (0.75)(472.5) = 354.4 \text{ k}$	$\frac{R_n}{\Omega} = \frac{472.5}{2.00} = 236.3 \text{ k}$

14.21 PROBLEMS FOR SOLUTION

Unless otherwise noted, A36 steel is to be used for all problems.

- 14-1. A 1/4-in fillet weld, SMAW process, is used to connect the members shown in the accompanying illustration. Determine the LRFD design load and the ASD allowable load that can be applied to this connection, including the plates, using the AISC Specification and E70 electrodes. (Ans. 97.2 k, 64.7 k)

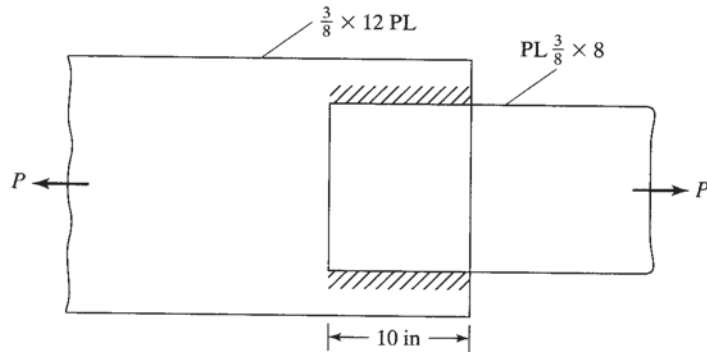

FIGURE P14-1

- 14-2. Repeat Prob. 14-1 if the weld lengths are 24 in.
 14-3. Rework Prob. 14-1 if A572 grade 65 steel and E80 electrodes are used.
 (Ans. 127.3 k, 84.8 k)
 14-4. Determine the LRFD design strength and the ASD allowable strength of the 5/16-in fillet welds shown, if E70 electrodes are used.

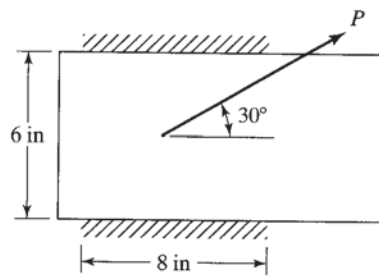

FIGURE P14-4

- 14-5. (a) Repeat Prob. 14-4 if 1/4-in welds are used and if $\theta = 45^\circ$. (Ans. 115.6 k, LRFD; 92.3 k, ASD)
 (b) Repeat part (a) if $\theta = 15^\circ$. (Ans. 95.0 k, LRFD; 63.3 k, ASD)
 14-6. Using both the LRFD and ASD methods, design maximum-size SMAW fillet welds for the plates shown, if $P_D = 40$ k, $P_L = 60$ k and E70 electrodes are used.

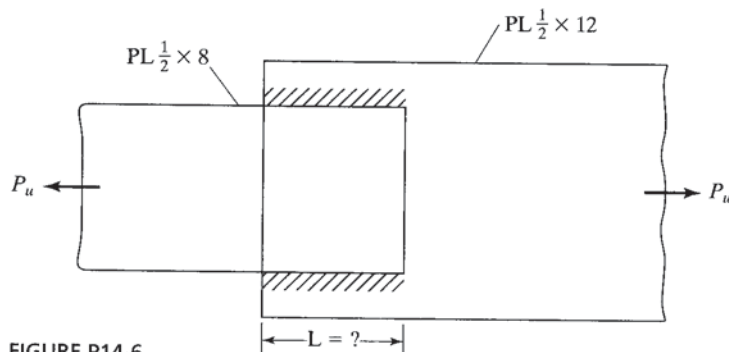

FIGURE P14-6

- 14-7. Repeat Prob. 14-6 if $\frac{5}{16}$ -in welds are used. (Ans. 10.5 in, 11 in)
- 14-8. Calculate ϕR_n for Prob. 14-6, using $\frac{5}{16}$ in side welds 8 in long and a vertical end weld at the end of the $\frac{1}{2} \times 8$ plate. Also use A572 grade 65 steel and E80 electrodes.
- 14-9. Rework Prob. 14-8, using $\frac{1}{4}$ in side welds 10 in long and welds at the end of the $\frac{1}{2} \times 8$ PL and E70 electrodes. (Ans. 161.5 k, 107.6 k)
- 14-10. The $5/8 \times 8$ -in PL shown in the accompanying illustration is to be connected to a gusset plate with $1/4$ -in SMAW fillet welds. Determine ϕR_n and $\frac{R_n}{\Omega}$ of the bar if E70 electrodes are used.

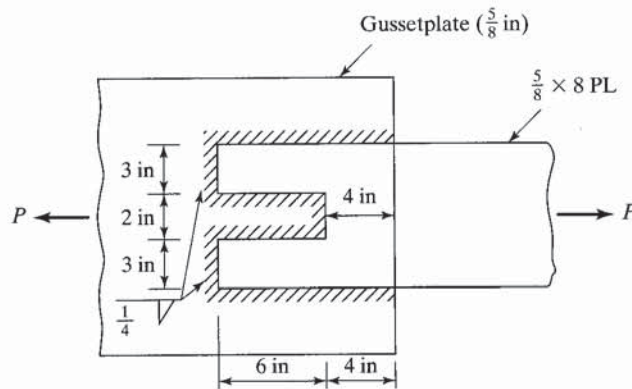

FIGURE P14-10

- 14-11. Design by LRFD and ASD maximum size side SMAW fillet welds required to develop the loads $P_D = 70$ k and $P_L = 60$ k for an $L6 \times 4 \times 1/2$, using E70 electrodes and 50 ksi steel. The member is connected on the sides of the 6-in leg and is subject to alternating loads. (Ans. $L_1 = 12.5$ in, $L_2 = 6.5$ in (LRFD); $L_1 = 13.5$ in, $L_2 = 7.0$ in (ASD))
- 14-12. Rework Prob. 14-11, using side welds and a weld at the end of the angle.
- 14-13. Rework Prob. 14-11, using E80 electrodes. (Ans. $L_1 = 11$ in, $L_2 = 5.5$ in (LRFD); $L_1 = 12$ in, $L_2 = 6$ in (ASD))
- 14-14. One leg of an $8 \times 8 \times 3/4$ angle is to be connected with side welds and a weld at the end of the angle to a plate behind, to develop the loads $P_D = 170$ k and $P_L = 200$ k. Balance the fillet welds around the center of gravity of the angle. Using LRFD and ASD methods, determine weld lengths if E70 electrodes and maximum weld size is used.
- 14-15. It is desired to design $5/16$ -in SMAW fillet welds necessary to connect a $C10 \times 30$ made from A36 steel to a $3/8$ -in gusset plate. End, side, and slot welds may be used to develop the loads $P_D = 80$ k and $P_L = 120$ k. Use both ASD and LRFD procedures. No welding is permitted

on the back of the channel. Use E70 electrodes. It is assumed that, due to space limitations, the channel can lap over the gusset plate by a maximum of 8 in. (Ans. $\frac{15}{16} \times 4$ in slot LRFD, $\frac{15}{16} \times 4\frac{1}{4}$ in slot ASD).

- 14-16. Rework Prob. 14-15, using A572 grade 60 steel, E80 electrodes, and 5/16-in fillet welds.
 14-17. Using the elastic method, determine the maximum force per inch to be resisted by the fillet weld shown in the accompanying illustration. (Ans. 11.77 k/in)

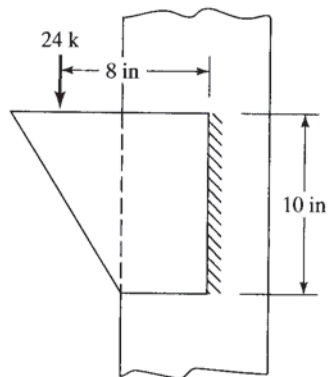

FIGURE P14-17

- 14-18. Using the elastic method, determine the maximum force to be resisted per inch by the fillet weld shown in the accompanying illustration.

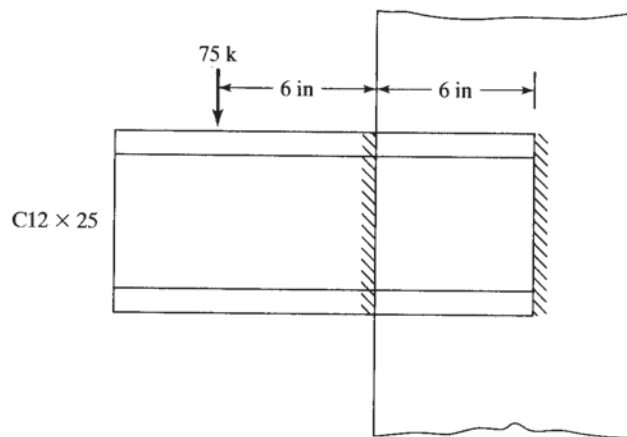

FIGURE P14-18

- 14-19. Using the elastic method, rework Prob. 14-18 if welds are used on the top and bottom of the channel in addition to those shown in the figure. (Ans. 5.88 k/in)

- 14-20. Using the elastic method, determine the maximum force per inch to be resisted by the fillet welds shown in the accompanying illustration.

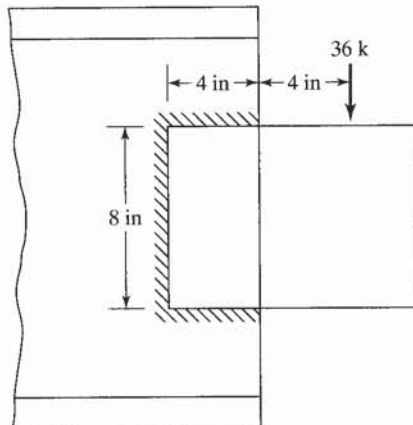

FIGURE P14-20

- 14-21. Determine the maximum eccentric loads ϕP_n that can be applied to the connection shown in the accompanying illustration if 1/4-in SMAW fillet welds are used. Assume plate thickness is 1/2 in and use E70 electrodes. (a) Use elastic method. (b) Use AISC tables and the ultimate strength method. (Ans. (a) 27.0 k, (b) 62.4 k)

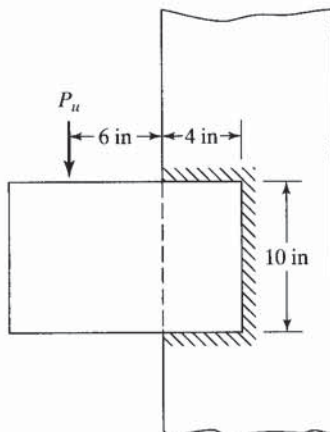

FIGURE P14-21

- 14-22. Rework Prob. 14-21 if 5/16-in fillet welds are used and the vertical weld is 8 in high.
- 14-23. Using the LRFD method and E70 electrodes, determine the fillet weld size required for the connection of Prob. 14-17 if $P_D = 10$ k, $P_L = 10$ k, and the height of the weld is 12 in. (a) Use elastic method. (b) Use AISC tables and the ultimate strength method. (Ans. (a) 7/16 in, (b) 1/4 in)

- 14-24. Repeat part (a) of Prob. 14-23, using the ASD method.
- 14-25. Using E70 electrodes and the SMAW process, determine the LRFD fillet weld size required for the bracket shown in the accompanying illustration. (a) Use elastic method. (b) Use AISC tables and the ultimate strength method.
 (Ans. (a) 3/8 in, (b) 1/4 in)

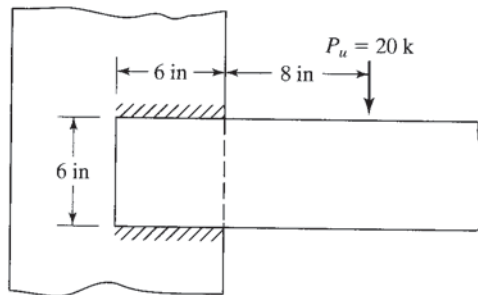

FIGURE P14-25

- 14-26. Rework Prob. 14-25 if the load is increased from 20 to 25 k and the horizontal weld lengths are increased from 6 to 8 in.
- 14-27. Rework Prob. 14-25, using ASD with $P_u = 11$ k. (Ans. (a) 5/16 in, (b) 3/16 in)
- 14-28. Using LRFD only, determine the fillet weld size required for the connection shown in the accompanying illustration. E70. (a) Use elastic method. (b) Use AISC tables and the ultimate strength method.

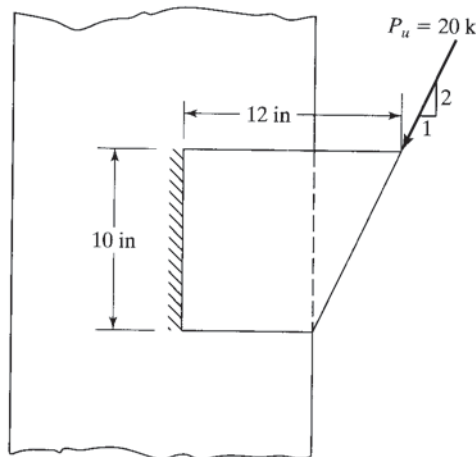

FIGURE P14-28

- 14-29. Using the ASD method only, determine the SMAW fillet weld size required for the connection shown in the accompanying illustration. E70. What angle thickness should be used? (a) Use elastic method. (b) Use AISC tables and the ultimate strength method. (Ans. (a) 3/16 in, (b) 1/8 in)

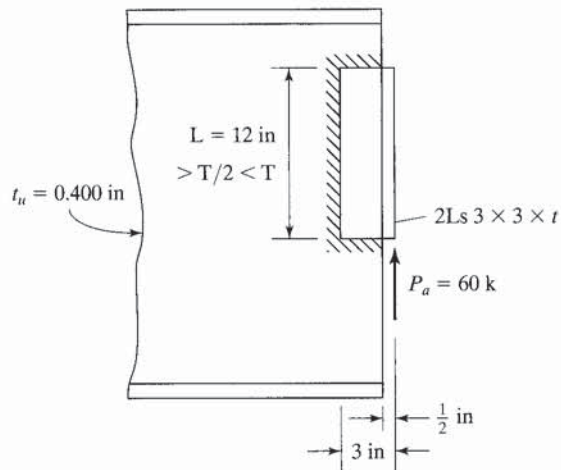

FIGURE P14-29

- 14-30. Assuming that the LRFD method is to be used, determine the fillet weld size required for the connection shown in the accompanying illustration. Use E70 electrodes and the elastic method.

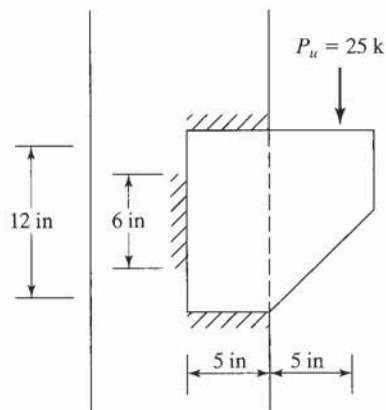

FIGURE P14-30

- 14-31. Determine the fillet weld size required by the ASD method for the connection shown in the accompanying illustration. E70. The SMAW process is to be used. (a) Use the elastic method. (b) Use ASD tables and the ultimate strength method. (Ans. (a) 3/8 in, (b) 3/16 in)

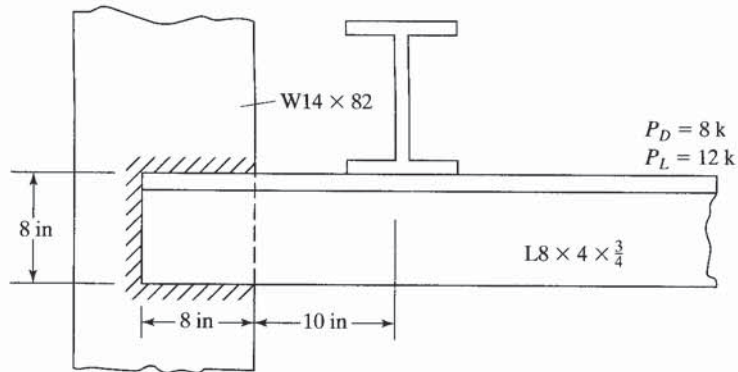

FIGURE P14-31

- 14-32. Determine the value of the loads ϕP_n and P_n/Ω that can be applied to the connection shown in the accompanying illustration if 3/8-in fillet welds are used. E70. SAW. Use the elastic method.

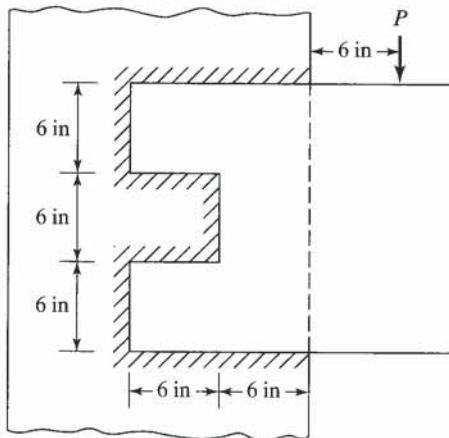

FIGURE P14-32

- 14-33. Using LRFD and ASD, determine the length of 1/4-in SMAW E70 fillet welds 12 in on center required to connect the cover plates for the section shown in the accompanying illustration at a point where the external shear V_u is 80 k and $V_a = 55$ k. E70. (Ans. 2.5 in both LRFD & ASD)

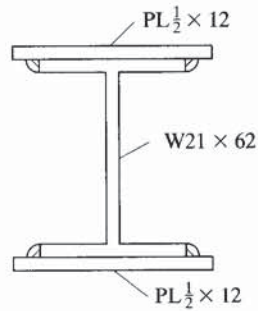

FIGURE P14-33

- 14-34. The welded girder shown in the accompanying illustration has an external shear $V_D = 300$ k and $V_L = 350$ k at a particular section. Determine the fillet weld size required to fasten the plates to the web if the SMAW process is used. E70. Use LRFD and ASD.

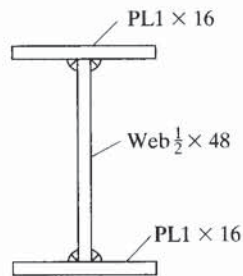

FIGURE P14-34

- 14-35. (a) Using both LRFD and ASD procedures and assuming the A36 plates in Fig. 14.29 are 12 in wide and 1/2 in thick, determine their design tensile strength and their ASD allowable strength if a full-penetration groove weld is used. Use E70 electrodes.
 (b) Repeat if a 5/16-in partial-penetration groove weld is used on one side.
 (Ans. (a) 194.4 k (LRFD); 129.3 k (ASD), (b) 75.6 k (LRFD); 50.3 k (ASD))
- 14-36. (a) If full-penetration groove welds formed with E70 electrodes are used to splice together the two halves of a W24 x 117, determine the shear strength capacity of the splice using both the LRFD and ASD procedures. Use SMAW weld process, $F_y = 50$ ksi, $F_u = 65$ ksi.
 (b) Repeat part (a) if two vertical partial-penetration groove welds (45° Bevel) with 1/4 in throat thickness are used.